

CEMO CUBE diesel tank system PG 4

Diesel



CUBE diesel tank system 10,000 L Outdoor Premium



Suction hose with connection to first tank and switching valves included in the expansion unit.

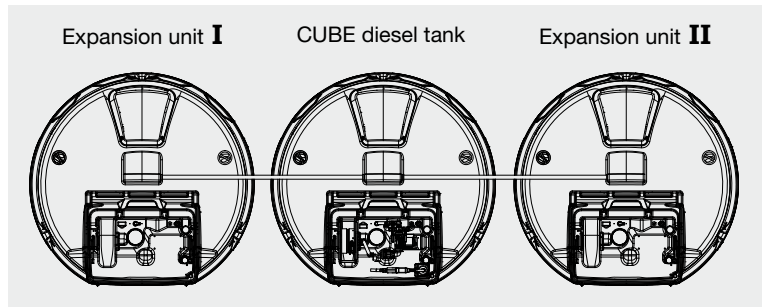

CUBE diesel filling station 15,000 L with expansion unit I and II

CUBE DIESEL TANK SYSTEM 10,000 L AND 15,000 L

Description	Comprising	Delivery rate L/min *	External dimensions cm (w x d x h)	Weight approx. kg	Order no.
10,000 L Outdoor Premium	CUBE diesel dispensing station Outdoor Premium (11079) and CUBE expansion unit I Outdoor (11081)	72	500 x 230 x 185	413	11097
15,000 L Outdoor Premium	CUBE diesel dispensing station Outdoor Premium (11079) and CUBE expansion unit I Outdoor (11081) and CUBE expansion unit II Outdoor (11096)	72	760 x 230 x 185	614	11098

Accessories see page 20.

* Pump output in free flow. Please note that the pump output can fall sharply depending on the length and cross-sectional area of the hose.