

# PIUSI 3000 SUPREME



## READY FOR A NEW GENERATION OF REFUELLING PUMPS?

### THE PROBLEMS TYPICALLY ASSOCIATED WITH REFUELLING FROM TRANSPORTABLE TANKS

1. **Security:** is the pump operated by a simple ON button, making it susceptible to unauthorised fuel withdrawals?
2. **Unknown withdrawals:** are you in doubt about who has withdrawn fuel and when?
3. **Overheating:** does the pump overheat when dispensing fuel to vehicles with large fuel tanks?
4. **Failures or malfunctions:** has the pump suffered damage as a result of being connected to the wrong voltage?

### PIUSI 3000 SUPREME IS THE SOLUTION!

1. **Dedicated app** - Secure, controlled and traceable fuel access, only to authorised users in possession of a security PIN
2. **Flow Control Technology** - Automatically reduces the flow rate in the event of overheating. You can also reduce the flow rate manually, from an app, if you want to dispense fuel into small cans
3. **Multi-Battery Technology** - Multi-voltage power supply from 12V to 24V\*, with protection in the event of connection with reversed polarity

\* The Piusi 3000 Supreme does not have the ability to monitor the battery and does not provide any type of protection for it.





### 3 VERSIONS COVERING A FULL RANGE OF NEEDS

	SITE DIMENSIONS		
	1 pump		2 or more pumps
	PIUSI SUPREME	PIUSI SUPREME PRO	B.SMART
Integrated flow control	✓	✓	✓
Login with security PIN	✓	✓	✓
Delivery time-out	✓	✓	✓
Preset function	✓	✓	✓
User Management	Up to 2 users	Up to 10 users	Up to 500 users for each dispenser, unlimited in the system
Dispense history	Last 20	Latest 100, downloadable with CSV file	Filterable report by date
Dispense calendar	-	✓ in the app	✓ in the webapp with filterable report by date
Total dispensed	-	✓ in the last 30 days	✓ Filterable report by date
In-app reminder/To do list	-	✓	-
Level indicator management	-	-	✓ with the TANK WATCHDOG add-on
Consumption management of vehicles and users	-	-	✓ with the FUEL ECONOMY add-on
Geolocation of dispenses	-	-	✓ with the MAPLY add-on

It is possible to upgrade to the higher version even after purchasing the pump

### SOFTWARE UPGRADE (ONE TIME FEE)

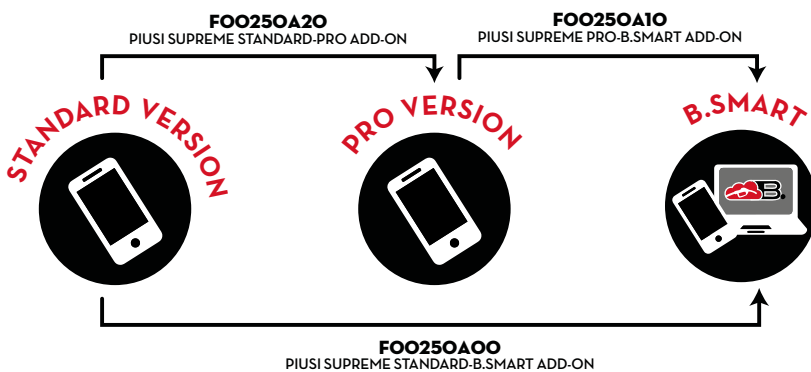

### ALREADY IN B.SMART?

Buy a Discovery B.SMART ADD-ON for each PIUSI 3000 SUPREME and add it to your site code.



**FOO770S00**  
PIUSI SUPREME DISCOVERY B.SMART  
+10 DRIVERS INCLUDED



FUEL MANAGEMENT SYSTEMS



DISPENSERS



KITS



PUMPS



METERS



NOZZLES

# PIUSI 3000 SUPREME

## FEATURES

- VOLTAGE FROM 12 TO 24V\*
- BLUETOOTH CONNECTION
- TOTAL CONTROL VIA APP
- VIBRATION RESISTANCE
- LOW NOISE
- COMPATIBLE WITH DIESEL UP TO B20 - HVO/XTL
- MAX. PRESSURE 1,5 BAR
- IP55

The **PIUSI 3000 SUPREME** is a highly innovative device designed to offer full pump control and management from a smartphone app, thus helping users fill up with diesel from mobile tanks quickly and safely.

The PIUSI 3000 SUPREME combines new digital technologies with PIUSI's long and proven track-record in the design of fluid management systems such as pumps and flow meters. This new pump is designed to dispense diesel, measure the volume dispensed, manage operator access and solve the problems typically faced by users of transportable tanks.

## PERFORMANCE

UP TO <b>50 L/MIN</b>	FROM <b>12V TO 24V*</b>
FLOW RATE	VOLTAGE
CONTINUOUS DUTY	<b>±0,5%</b>
DUTY CYCLE	ACCURACY

\* The Piusi 3000 Supreme does not have the ability to monitor the battery and does not provide any type of protection for it.



PIUSI 3000 SUPREME



## PACKAGING

CODE	WEIGHT		PACKAGING		
	KG	LBS	MM	INCH	PCS/BOX
FO0250H00	8	17,6	270X190X180	-	1
FO0250V00	8	17,6	270X190X180	-	1
FO0250D00	8	17,6	300X300X180	-	1
FO0250K00	15	33	490X390X310	-	1
FO0250D10	15	33	490X390X310	-	1



FILTRATION



TANK MONITORING



HOSE REEL



ACCESSORIES



MERCHANDISE



ANY BIODIESEL



AIR



ANTIFREEZE



AdBlue®



BIODIESEL



DIESEL



FOOD



GASOLINE



GREASE



KEROSENE



OIL



WATER



WINDSCREEN



BASE BRACKET KIT



2" DIRECT MOUNT KIT

### DIMENSIONS

#### BASE BRACKET KIT

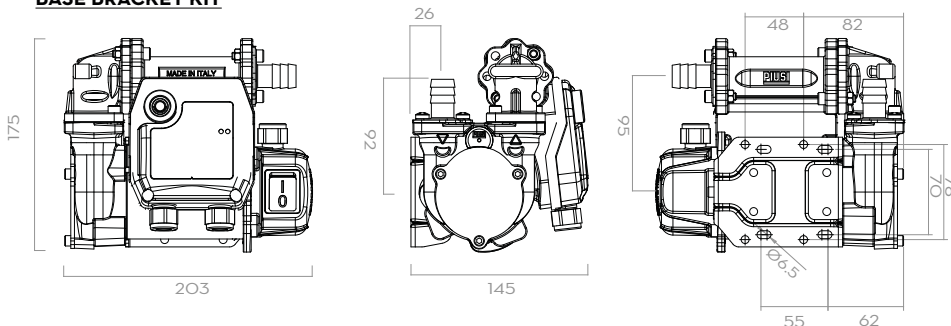

#### 2" DIRECT MOUNT KIT

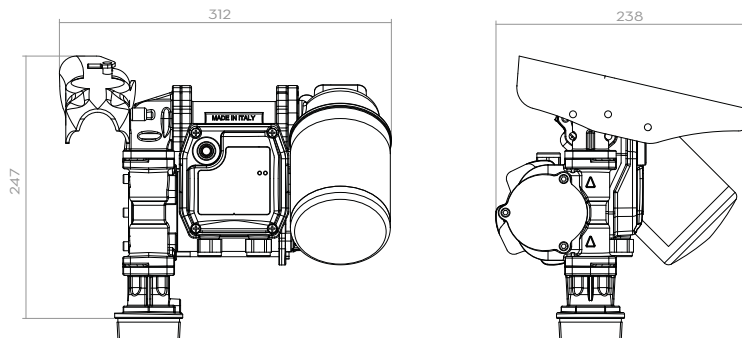

Dimensions expressed in millimeters

### IN THE BOX

- PUMPS
- SUCTION FILTER (BASE BRACKET KIT)
- DELIVERY HOSE
- AUTOMATIC NOZZLE A60
- ELECTRIC CABLE 4M
- OIL & FUEL FILTER (2" DIRECT MOUNT)
- 2" SUCTION CONNECTION (2" DIRECT MOUNT KIT)
- BASE BRACKET (BASE BRACKET KIT)
- NOZZLE HOLDER (2" DIRECT MOUNT KIT)
- ACCESS KEY (IPZ)
- INSTRUCTION MANUAL

### DETAILS



BENDING PROTECTION



ELECTRIC CABLE

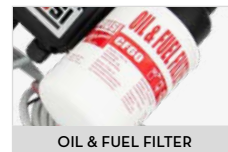

OIL & FUEL FILTER



AUTOMATIC NOZZLE A60

### COMPONENTS

- BODY: CAST IRON
- ROTOR: SINTERED STEEL
- VANES: ACETAL RESIN
- SEAL: NBR
- SHAFT: STEEL

### ACCESSORIES

- AUTOMATIC NOZZLE A60 + HOOK  
COD. F00603S00 (2" DIRECT MOUNT KIT)
- AUTOMATIC NOZZLE A60 COD. F00603O60  
(BASE BRACKET KIT)
- DIESEL HOSE 4M (COD. F24103000)

### TECHNICAL DATA

CODE	DESCRIPTION	FLUIDS TYPE	FLOW RATE		VOLTAGE			RPM	DUTY CYCLE CONTINUOUS	FUSES CAPACITY AMPERE	HOSE		SPIN ON FILTER	NOZZLE
			L/MIN	GPM	DC VOLT	POWER WATT	AMP. MAX.				LENG.	Ø		
F00250H00	PIUSI 3000 SUPREME PUMP ONLY B.O.	D	50	13	FROM 12 TO 24	200W	16A/8A	2700	YES	25A	-	-	-	-
F00250V00	PIUSI 3000 SUPREME PUMP ONLY B.V.	D	50	13	FROM 12 TO 24	200W	16A/8A	2700	YES	25A	-	-	-	-
F00250D00	PIUSI 3000 SUPREME PUMP ONLY DRUM	D	50	13	FROM 12 TO 24	200W	16A/8A	2700	YES	25A	-	-	YES	-
F00250K00	PIUSI 3000 SUPREME BASE BRACKET KIT	D	50	13	FROM 12 TO 24	200W	16A/8A	2700	YES	25A	4MT	3/4"	-	A60
F00250D10	PIUSI 3000 SUPREME 2" DIRECT MOUNBT KIT	D	50	13	FROM 12 TO 24	200W	16A/8A	2700	YES	25A	4MT	3/4"	YES	A60