



Operating manual

# Hand Pump

## K 10 C

Item No.: 103 083 000, 103 089 000, 103 089 100

Translation of the  
original operating manual  
GB

---

## **Important!**

---

**The operating manual is always to be read before commissioning the equipment. No warranty claim will be granted for faults and damage to the equipment arising from insufficient knowledge of the operating manual.**

---

## **Copyright**

---

© HORN GmbH & Co. KG. All rights reserved.

Text, graphics and layout copyright protected. Reproduction and copying, including in part, only permitted with written permission. Technical changes reserved.

---

**Service Hotline      +49 1805 900 301**

(0,14 €/Min: on the German landline network, Mobile telephone max. 0,42 €/Min.)

**[service@tecalem.it](mailto:service@tecalem.it)**

---

Document-No.:      44 0423 002-G  
As of:                09.02.2015

## Table of content

<b>1</b>	<b>Safety instructions</b> .....	<b>3</b>
<b>2</b>	<b>Product description</b> .....	<b>5</b>
	2.1 Product versions.....	5
	2.2 Permitted media .....	5
	2.3 Technical data.....	5
	2.4 Environment.....	5
	2.5 Accessories .....	6
<b>3</b>	<b>Assembly</b> .....	<b>7</b>
	3.1 Assembly instructions.....	7
	3.2 Securing against unauthorised use .....	7
<b>4</b>	<b>Operation</b> .....	<b>8</b>
	4.1 Commissioning.....	8
	4.2 Normal operation .....	8
<b>5</b>	<b>Maintenance</b> .....	<b>8</b>
<b>6</b>	<b>Disposal</b> .....	<b>8</b>
<b>7</b>	<b>Spare parts</b> .....	<b>9</b>
<b>8</b>	<b>Declaration of confirmity</b> .....	<b>11</b>

## 1 Safety instructions

The device is a state of the art piece of equipment and has been constructed according to recognised safety specifications. It is nevertheless possible that use of the device will present hazards to the operator or to third parties, or may damage the device or other property. It is therefore essential to act in accordance with these safety instructions, and in particular with those sections identified as warnings.

### Warning notices and symbols

In the operating manual, the following signs are used for highlighting important information.



**Special information for economical use of the equipment.**



**Special information or "dos and don'ts" for damage prevention.**



**Information or "dos and don'ts" for the prevention of damage to persons or equipment.**

### Appropriate use



The device may only be used if it is in perfect condition, and then only for its intended purpose, in compliance with all safety regulations, with an awareness of the potential risks, and according to the operating manual. Any faults that may impair the safety must be rectified immediately.



The device and its components are only to be used for handling the liquids listed and the purpose described. Using the machine for any other purpose would constitute inappropriate use. The manufacturer is not responsible for any loss arising as a result of this, the risk for this is borne only by the operating company.

---

## Organisational measures

---

- ! This operating manual should always be kept readily available at the site of operation! Each person concerned with the assembly, commissioning, maintenance and operation of the equipment must have read and understood the entire operating manual. It is essential that the type plate and the warning notices attached to the device are observed, and are maintained in a fully readable condition.

---

## Qualified personnel

---

- ! The operating, maintenance and assembly personnel must be appropriately qualified for their work. The areas of responsibility, competences and supervision of the personnel must be precisely regulated by the operating company. If the personnel do not have the required knowledge, they must be trained and instructed. The operating company must also ensure that the contents of the operating manual are properly understood by the personnel.

---

## Waters protection

---

-  The device has been designed to handle water hazardous substances. The regulations on the operating place (e.g. Water Resources Act WHG, = ordinance on installations for handling of substances hazardous to water VAWS) must be adhered to.

---

## Hydraulics

---

-  Only persons with special knowledge and experience with hydraulic systems may carry out work on hydraulic parts and equipment. All lines, hoses and screw joints should regularly be checked for leaks and visible external damage. Any damage must be rectified immediately. Any oil spurting out can cause injuries and fire.
- The relevant safety regulations for the product must be followed when handling oils, greases or other chemical substances!

---

## Maintenance and Service

---

-  According to the regulations of the water resources law only authorized services may work on devices for flammable and/or water endangering substances. During such works, appropriate tools are to be used (avoid sparking). Before any kind of work on the device, all fuel lines are to be completely emptied and aerated.
- Do not make any changes. Modifications or additions to the device which may affect the safety cannot be carried out without consent of the manufacturer. Exclusively genuine spare parts made by the manufacturer may be used.

---

## Electric power

---

-  Work on the electrical equipment may only be carried out by a qualified electrician or by trained persons under the guidance and supervision of a qualified electrician according to electro-technical guidelines. Machine or system components, on which inspection, maintenance or repair work is to be carried out must be de-energised.

## 2 Product description

The K 10 C is a single-action hand pump for pumping the media listed below from barrels, drums and overground storage tanks. The M64 x 4 and G2" threads integrated in the housing enable simple assembly. The K 10 C is available with two different suction pipes.

### 2.1 Product versions

103 083 000	K 10 C with suction pipe for immersion depths of 840 mm, fits to 200 l upright drums.
103 089 000	K 10 C with telescopic suction pipe for immersion depths between 470 and 925 mm.
103 089 100	K 10 C Kit with telescopic suction pipe for immersion depths of 470 mm to 925 mm with hose fitting, 1.5 m DN 19 x 4, incl. outlet elbow AK 20 and bend protect spring (approved for use in areas at risk of explosion)

### 2.2 Permitted media

The K 10 C may be operated with the following media (hazard classes A I - III): Diesel, heating oil EL/L, fuels, petroleum, antifreeze (undiluted), low viscosity mineral oils and RME.

### 2.3 Technical data

<b>Pump dimensions</b>	<b>Height</b>	approx. 257 mm
	<b>Diameter</b>	approx. 92 mm
<b>Immersion depth</b>	<b>Stiff suction pipe</b>	840 mm
	<b>Telescopic suction pipe</b>	470 - 925 mm
<b>Barrel connection</b>	<b>Thread</b>	M64x4 / G2"
<b>Pump type</b>		Single-action piston pump
<b>Pumping capacity</b>		approx. 0.25 l/stroke
<b>Permissible ambient temperature</b>		-20° - +40° C
<b>Permissible media temperature</b>		Depends on medium (hazard class AI to AIII); min. -20°C max.+40°C

### 2.4 Environment

The hand pump K 10 C is approved for use in explosive areas.



II 2/2G c IIA T3



**Make sure that all components required for the environment in which the pump will be used are approved.**

---

## 2.5 Accessories

---

- 209 060 030 Potential equalisation cable 2 m
- 245 040 000 FT 20 filter  
for K 10 C
- 308 103 100 Hose fittings  
1.5 m DN 19 x 4 HORN 40 X,  
with outlet elbow AK 20 and anti-kink spring  
approved for use in explosive areas
- 316 103 100 Hose fittings  
1.5 m DN 19 x 4 HORN 365 X,  
elec. conductive (hazard class A I - III),  
with outlet elbow AK 20 and anti-kink spring
- 316 303 100 Hose fittings  
1.5 m DN 19 x 4 HORN 365 X,  
elec. conductive (hazard class A I - III),  
with outlet valve AV 20 and anti-kink spring
- 320 303 100 Hose fittings  
1.5 m DN 19 x 4, LZ19 with insert,  
elec. conductive (hazard class A I - III),  
with outlet valve AV 20 and anti-kink spring  
RME-resistant

### 3 Assembly

Remove completely the packing material, and you obey then the instruction for assembly:

#### 3.1 Assembly instructions

##### Suction Connection

Screw suction tube (4) in suction face of the pump pivot. (6)

Optional: Place suction filter (1) on suction pipe (2) and fix with hose clamp (3). (Suction filter (1) and hose clamp (3) are optional accessories )

##### Pressure connection

Place Hose clamp (10) and break protection spring on black pressure hose (8) and push it onto the female connector of the pump. Fix spring with bent wire (9) and hose clamp (10). Secure hose by tightening the bolt on the hose clamp.

Screw the pump onto the upright barrel.

**Optional:** screw potential equalisation cable tightly to the pump.



**If the pump is to be used in areas at risk of explosion, it is compulsory that a potential compensation cable is used.**



**Operation without filter is not permitted. An exception may only be made when it has been ensured that only clean media will be delivered.**

#### 3.2 Securing against unauthorised use

The pump lever can be locked to the pump head with a conventional padlock (the lock is not included in the scope of supply).

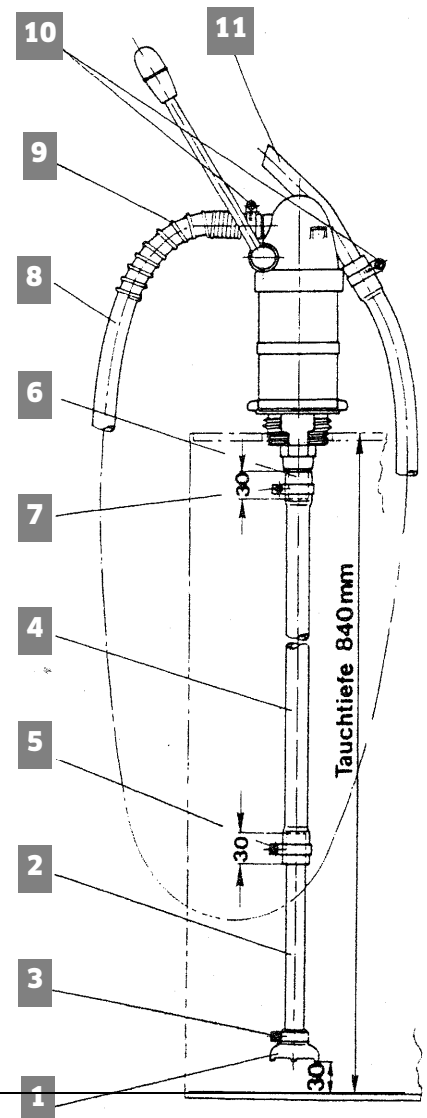

## 4 Operation



**During use in potentially explosive areas, every pump and container should be earthed prior to commissioning or provided with a potential equalisation between themselves and earthed altogether.**

The potential equalisation of the pump can take place with the potential equalisation cable, item no. 209 060 030, which is available as an accessory. Attention should be paid to a highly conductive transition at the connection points of the potential equalisation cable.

### 4.1 Commissioning

Place the outlet pipe into a tank or other suitable container.

Move the lever backwards and forwards until medium emerges from the outlet pipe.



**Operation without filter is not permitted. An exception may only be made when it has been ensured that only clean media will be delivered.**



**Make sure that the pump does not become hot when sucking - danger of explosion.**



**Make sure that no inadmissible heated up media are pumped - danger of explosion.**



**Continuous dry running can cause the damage of the pump.**

### 4.2 Normal operation



**Make sure that no inadmissible heated up media are pumped - danger of explosion.**



**Continuous dry running can cause the damage of the pump.**

Move the lever backwards and forwards until the desired quantity has been pumped out.

## 5 Maintenance

- As soon as the pumped quantity falls off noticeably, check the filter in the suction pipe and clean it if necessary.
- Regularly check for leaks at the discharge hose and at the connecting elements. Faulty seals or hoses must be exchanged immediately.

## 6 Disposal

The device is to be emptied completely and the liquids properly disposed of in case it is taken out of service.

The equipment is to be disposed of properly when taken permanently out of service:



- Return old metal for recycling.
- Return plastic parts for recycling.
- Return electronic waste for recycling.



**The water legal regulations are to be followed.**



## 7 Spare parts

<b>Item</b>	<b>Item no.</b>	<b>Description</b>
1	604230005	Top part
2	804238003	Complete cylinder; consisting of cylinder item 2 and steel ball and set pin item 12
3	593990001	Piston; see also item 100, piston complete
4	592710001	Valve plate
5	690830001	Shaft
6	804238001	Rocker arm assembly with rivet and connecting rod
7	593790001	Gudgeon pin
8	690809001	Hand lever
10	TEXT	Caution!!! Not available separately ! Items 10 and 10a are part of the rocker arm assembly item 6.
13	591840001	Spring
15	403220800	Circlip D 8x0.8 DIN 471 steel
16	404009500	Sealing ring D.65x74x2
17	604230010	Sealing cord 4x4x195 Ramilon - see also item 110, sealing cord sold by the metre
18	404104000	O-Ring D.15.5x3 Perbunan petrol resistant
19	591690001	Handle
20	403202200	Washer D.6.4 DIN 433 St. galvanised.
21	403740100	Split pin D.1.6x10 DIN 94 St. galvanised.
100	804238002	Piston assembly consisting of: Item 3, 4, 7, 13, 15, 17, 20, 21
110	404901200	Pack Ramilon 4x4
120	404103500	O-Ring D.14x2.5 Perbunan for telescopic suction pipe TR 1/1
130	404104400	O-Ring D.17.3x2.4 Viton for telescopic suction pipe TR 2/1 + TR2/2
		The seal set for K10C consists of: 1 off item 16 #404009500 1 off item 17 #604230010 2 off item 18 #404104000

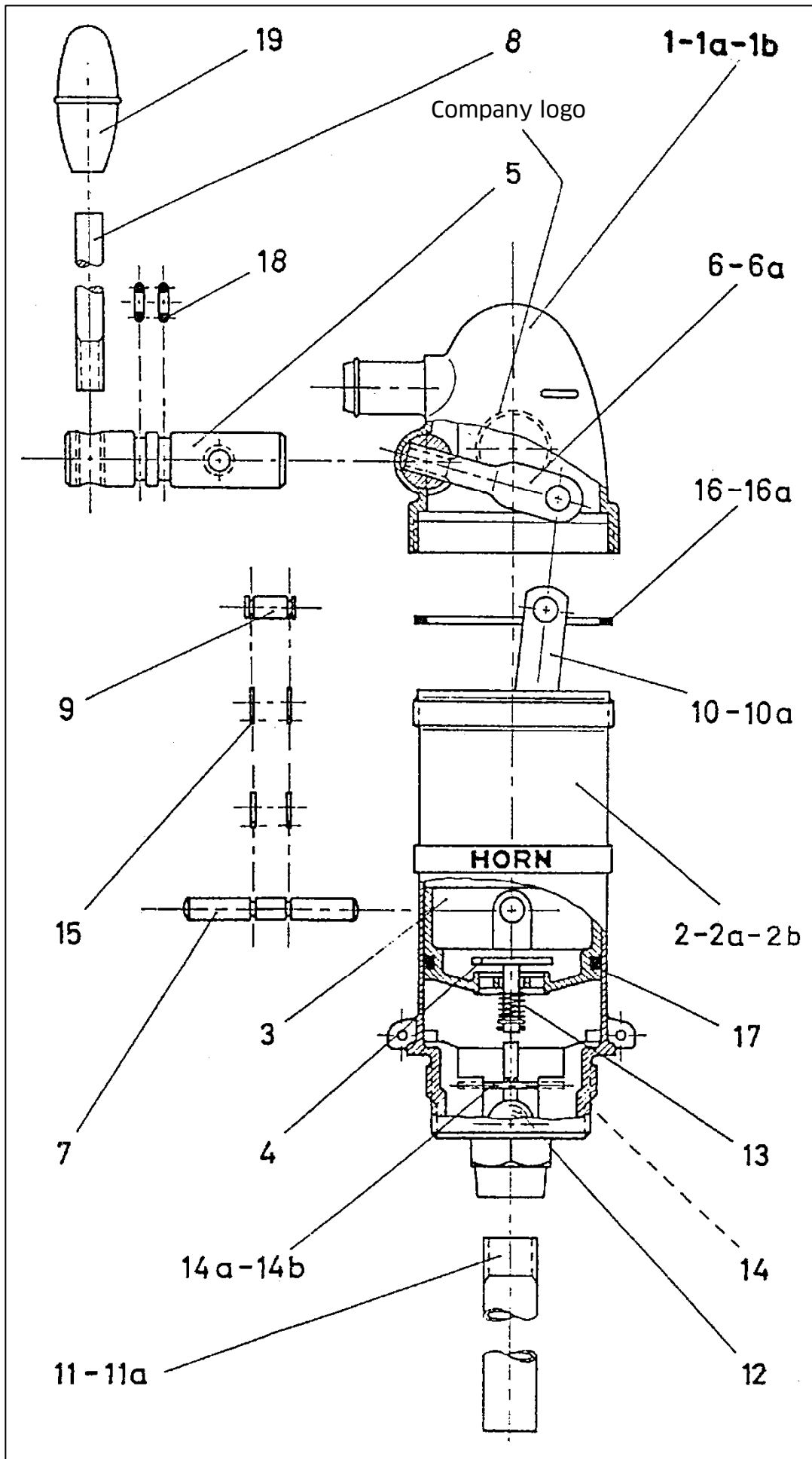

## 8 Declaration of conformity



### Konformitätserklärung Declaration of Conformity

Hiermit erklären wir, dass die Bauart  
*We hereby declare that the construction type*

Typ: <i>Type:</i>	<b>K 10 C</b> <b>K 10 C</b>
Bezeichnung: <i>Designation:</i>	<b>Handpumpe</b> <b>hand pump</b>
Artikel-Nr.: <i>Item No.:</i>	<b>103 083 000, 103 089 000</b>

in der von uns gelieferten Ausführung folgenden einschlägigen Bestimmungen entspricht:  
*in the form as delivered by us complies with the following applicable regulations:*

- ATEX 94/9/EG  
*ATEX 94/9/EC*

Das Produkt ist ein Gerät im Sinne 94/9/EG, Artikel 1, 3 a) und erfüllt die grundlegenden Sicherheits- und Gesundheitsanforderungen gemäß 94/9/EG, Anhang II.  
*The product is a device in scope of 94/9/EC, Article 1, 3 a) and complies with the essential health and safety requirements of 94/9/EC, Annex II.*

Angewendete harmonisierte Normen:  
*Applied harmonised standards:*

EN 1127-1      EN 13463-1      EN 13463-5

Kennzeichnung des Geräts gemäß EN 13463-1 / *Labeling of the device according to EN 13463-1:*

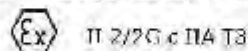

Die Produktion der Geräte unterliegt der internen Fertigungskontrolle gemäß 94/9/EG, Anhang VIII, die technischen Unterlagen nach 94/9/EG, Anhang VIII, Absatz 3, wurden bei einer benannten Stelle hinterlegt.  
*The devices are manufactured according to the internal control of production, 94/9/LL, Annex VIII. The technical documents provided in 94/9/EC, Annex VIII, paragraph 3, have been deposited at a notified body.*

EG-Dokumentationsbevollmächtigter:      Jörg Mohr      Horn GmbH & Co. KG  
*EC official agent for documentation:*      Munkwitz 42  
24937 Flensburg

4.8.2011

Datum  
*Date*

  
.....  
i.V. Dipl.-Ing. Jörg Mohr  
Entwicklungsleiter / *Engineering Manager*

HORN GmbH & Co. KG  
Munkwitz 42  
D-24937 Flensburg  
Germany

T +49 461 8650-0  
F +49 461 8650-55  
info@tecalemit.de  
www.horn.com.de

Flensburg  
Torsøvej 1, Kulsbølstræk

Flensburg  
DLZ 215 400 60  
Konto Nr. 2476008

SWIFT: COOJAD33XXX  
IBAN: DE32 251 500 000 000 000 000 000  
Anliegen: Flensburg | SA 0204  
Use-IdNr. DE311019810

**HORN GmbH & Co. KG**

Munketoft 42  
24937 Flensburg  
Germany

T +49 461-8696-0  
F +49 461-8696-66

[www.tecalemit.de](http://www.tecalemit.de)  
[info@tecalemit.de](mailto:info@tecalemit.de)