

# CEMO diesel trolley

Mobile fuelling on site used to be a tricky topic. Apart from the question of transport, smaller quantities of fuel were easily spilled, depending on whether tank connections, funnels or hoses were used. The new CEMO tank trolleys are a completely different story. They deliver up to 100 litres of diesel fuel or petrol on site in absolute safety and in accordance with regulations.

Diesel



CAS battery

Totally mobile and cable free, independent of vehicle batteries.



integrated vent

The integrated vent system means that fuel can be taken out continuously without the trolley needing to be opened.



anti-kink protection + swivel joint + shut-off valve

The anti-kink protection and swivel joint provide the best possible protection for your delivery hose. The container can be completely closed with an isolation valve for transport.

**NEW**



nozzle holder

Integrated dispensing nozzle holder with lock.



recesses for lashing straps

Integrated guides for ratchet straps (100 L) provide safety for transport in the vehicle.

hose holder

Whether upright or horizontal – everything fits; no hose out of place.



all-terrain wheels

Large tyres for easy handling on terrain and over stairs.

# CEMO diesel trolley PG 4



**CENTRI SP30  
EXTREMELY  
QUIET**

Diesel

## Diesel trolley 60 L and 100 L

- suitable for use under ADR 1.1.3.1 c) for single-site refuelling by a person in the course of their primary business
- polyethylene container with integral hand grip and carry handles
- filler cap with integral vent and breather valve
- outlet connection with isolation valve
- trolley 100 L: 300mm diameter pneumatic tyres, all-terrain
- trolley 60 L: 240mm diameter plastic tyres
- internal baffle
- integral nozzle holder
- trolley 100 L: moulded recesses enabling strapping during transport

### Mounted pump:

- crank pump 0,38 L per revolution with 3m delivery hose DN 19 and nozzle
- self-priming pump CENTRI SP30, 12V, 30 L/min, extremely quiet, with 3m dispensing hose DN 19 and 4m fly leads or CAS battery



Diesel trolley 60 L with 12 V pump CENTRI SP30



Diesel trolley 100 L with 18 V pump CENTRI SP30 and CAS battery

Accessory: digital flow meter K24 for assembly between dispensing hose and automatic nozzle for the version with electric pump, see page 121.



Diesel trolley 60 L with crank pump

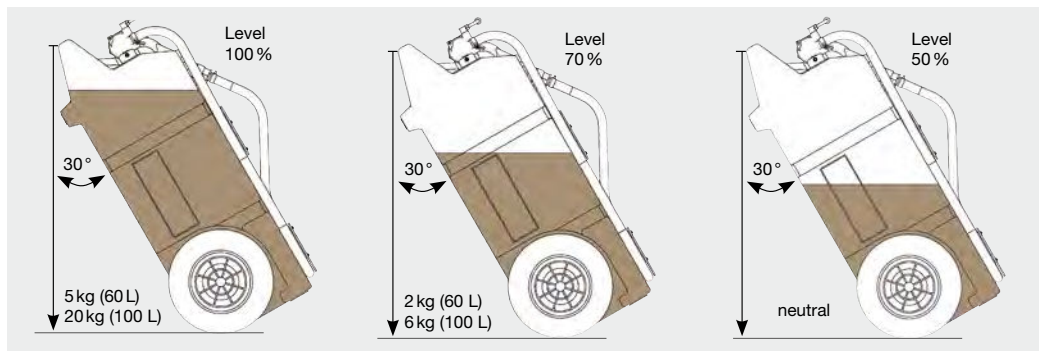

Weight distribution at handle while moving 60 L and 100 L trolley

## CEMO diesel trolley

Description/Capacity	Dimensions in cm (l x w x h)	Weight approx. kg	Order no.
60L, with crank pump and manual nozzle	90 x 53 x 38	15	11100
60L, with submersible pump 12 V CENTRI SP30 and automatic nozzle	90 x 53 x 38	15	11133
100L, with crank pump and manual nozzle	100 x 59 x 43	20	11101
100L, with submersible pump 12 V CENTRI SP 30 and automatic nozzle	100 x 59 x 43	20	11102

Description	Dispensing volume pump	Capacity of battery	Max. volume (litre) per battery charge	Dimensions in cm (l x w x h)	Order no.
charger and battery included					
diesel trolley 60 L <b>NEW</b>	30 L/min	2 Ah	360	90 x 53 x 38	11597
diesel trolley 100 L <b>NEW</b>	30 L/min	4 Ah	720	100 x 59 x 43	11598
Supplied without charger or battery – use your own CAS battery					
diesel trolley 60 L <b>NEW</b>	30 L/min	-	-	90 x 53 x 38	11590
diesel trolley 100 L <b>NEW</b>	30 L/min	-	-	100 x 59 x 43	11591

Accessory see page 44